

# CP 416s OD

## System Components

Number of Parallel Systems.....	2
Media Vessels (qty) Size.....	(4) 16 x 65"
Media Vessel Construction .....	Wrapped Polyethylene
Empty Bed Volume .....	6.55 ft <sup>3</sup>
Media / Vessel.....	4.0 ft <sup>3</sup> Non Solvent Cation Resin
Bed Depth / Free Board .....	50" / 15"
Riser Tube.....	1" ABS
Distributor Upper.....	0.014" Slots, ABS Basket
Lower.....	0.014" Slots, ABS Basket
Under bedding.....	0.75 ft <sup>3</sup> (75 lbs), ¼ x ½ Gravel
Regeneration Control.....	Non-electric Use Meter
Regeneration Type.....	Countercurrent
Meter Type.....	2.2 - 100.0 gpm Polypropylene Turbine

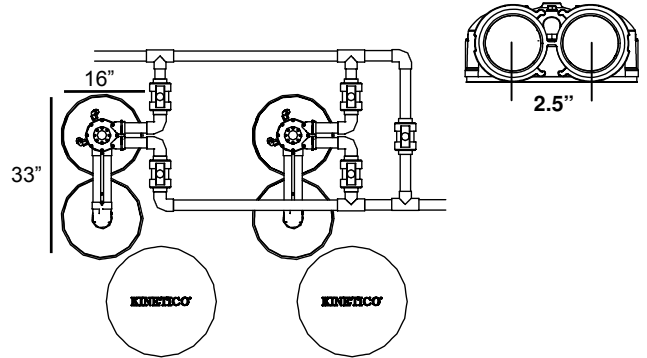

## Inlet Water Quality

Pressure Range .....	25 – 125 psi Dynamic Pressure
Temperature Range.....	35 – 120° F
pH Range .....	5 – 10 SU
Free Chlorine Cl <sub>2</sub> (Max.) .....	2.0 mg/l
Hardness as CaCO <sub>3</sub> (Max.) .....	49 gpg

## Operating Specs

Flow Range – Overdrive (15 / 30 psig) .....	70.0– 94.0 gpm
Flow Range – Alternating (15 / 30 psig).....	46.0 – 66.0 gpm
Unit Dimensions (width x depth x height).....	33 x 48 x 71"
Weight (Operating / Shipping).....	1300 / 900 lbs.

## Connections

Unit Inlet / Outlet Connections .....	Custom Adapter and E-Clip (1 ½" Brass Sweat Fittings Included)
Drain Connection .....	0.625" Tube
Brine Line Connection.....	0.375" Tube
Power .....	None

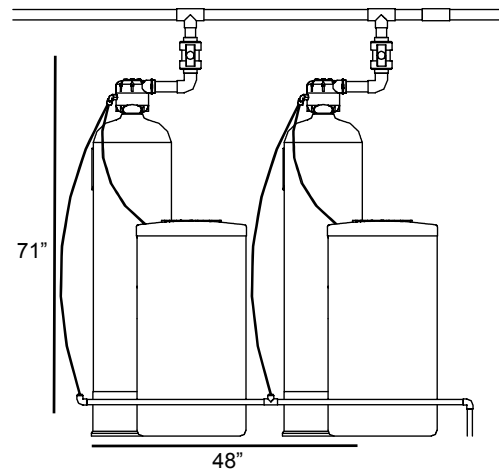

## System Part Numbers

CP 216s OD, 24 X 40 brine tank, media separate (qty).....	11182 (2)
CP 216s OD, no brine tank, media separate (qty) .....	11168 (2)
CP 216s OD, empty, no brine tank (qty).....	11186 (2)

## Brine Tank Options

Tank Description .....	24" x 40"
Brine Tank Part Number .....	10586
Material .....	HDPE
Salt Capacity.....	500 lbs.

## Regeneration Specifications

Regeneration Volume / Time .....	160 gallons / 90 minutes
Backwash Flow Control.....	7.00 gpm
Brine Refill Flow Control.....	0.70 gpm

## Overdrive Operation

Setting	Capacity	Efficiency	Dosing	Meter Disc
24 lbs.	88,000 grains	3,700 gr./lb.	6.0 lbs./ft <sup>3</sup>	
40 lbs.	112,000 grains	2,800 gr./lb.	10.0 lbs./ft <sup>3</sup>	
<b>Peak flow during regeneration:</b>				

## Alternating Operation

Setting	Capacity	Efficiency	Dosing	Meter Disc
24 lbs.	88,000 grains	3,700 gr./lb.	6.0 lbs./ft <sup>3</sup>	
40 lbs.	112,000 grains	2,800 gr./lb.	10.0 lbs./ft <sup>3</sup>	
<b>Flow during regeneration (@ 15 psig):</b>				
<b>Gallons/Regeneration:</b>				

## Disc Selection

(Compensated Hardness\*)

1	2	3	4	5	6	7	8
5	9	13	16	19	22	25	30
6	12	16	21	25	30	35	40
70	70	70	70	61.7	56.1	52.1	49.1

1	2	3	4	5	6	7	8
5	10	15	20	25	30	35	40
7	13	20	26	32	38	43	49
58	58	58	58	58	56.1	52.1	49.1
15,192	7,596	5,064	3,798	3,038	2,532	2,170	1,899

\*Compensated hardness in gpg = Hardness + (3 x Fe in mg/l)

## **Operating Profile**

Softener shall remove hardness to less than 1/2 gpg when operated in accordance with the operating instructions. The system shall include two sets of duplex systems (two tank systems). Each duplex configuration shall be flexible to operate in alternating or parallel mode depending on installed program disc. In alternating mode, one tank will be on-line during service. In parallel mode, both tanks will be on-line during service. With either mode, during regeneration cycles, one tank shall provide water to service and to the regenerating tank. A water meter shall initiate system regeneration. The water meter shall measure the processed volume and be adjustable. Service flow shall be down-flow and regeneration flow shall be up-flow.

## **Regeneration Control Valve**

The regeneration control valve shall be top mounted (top of media tank), and manufactured from non-corrosive materials. Control valve shall not weigh more than four pounds. Control valve shall provide service and regeneration control for two media tanks. Inlet and outlet ports shall accept a quick connect, double o-ring sealed adapter. Interconnection between tanks shall be made through the regeneration valve with a quick connect adapter. Control valve shall operate using a minimum inlet pressure of 25 psi. Pressure shall be used to drive all valve functions. No electric hook-up shall be required. Control valve shall incorporate four operational cycles including; service, brine draw, slow rinse, and a combined fast rinse and brine refill. Service cycle shall operate in a down-flow direction. The brine cycle shall flow up-flow, opposite the service flow, providing a countercurrent regeneration. Control valve shall contain a fixed orifice eductor nozzle and self-adjusting backwash flow control. The control valve will prevent the bypass of hard water to service during the regeneration cycle.

## **Media Tanks**

The tanks shall be designed for a maximum working pressure of 125 psi and hydrostatically tested at 300 psi. Tanks shall be made of polyethylene and reinforced with a fiberglass wrapping. Each tank shall include a 4.0 in. threaded top opening and a 2.5" x 4.0" tank adapter fitting. Each tank shall be NSF approved. Upper and lower distribution system shall be of a slot design. Distributors will provide even flow of regeneration water and the collection of processed water.

## **Conditioning Media**

Each softener shall include a non-solvent, high capacity cation resin having a minimum exchange capacity of 30,000 grains/ft<sup>3</sup> when regenerated with 15.0 lbs/ft<sup>3</sup>. The media shall be solid, of a proper particle size and shall contain no plates, shells, agglomerates or other shapes, which might interfere with the normal function of the water softener.

## **Brine System**

A combination salt storage and brine production tank shall be manufactured of corrosion resistant, plastic. The brine tank shall have a chamber to house the brine valve assembly. The brine float assembly shall allow for adjustable salt settings and shall provide for a shut-off to the brine refill. The brine tank shall include a safety overflow connection to be plumbed to a suitable drain.